

# SERIES SPIDER 18.90

## The Best solution for the maintenance of your house and garden

- Available with KUBOTA diesel engine with liquid cooling
- Available in bi-energy Electric version with 230Vac motor and Lithium-technology batteries
- Easy access to each component for simplified maintenance
- Easy to use with precise and proportional controls
- Equipped with flying jib without any basket capacity restriction
- Air/water and 230Vac outlets are available into the basket
- Fully protected by metal covers against falling objects
- Cranked outrigger design for increased ground clearance
- Quick detach and interchangeable cage

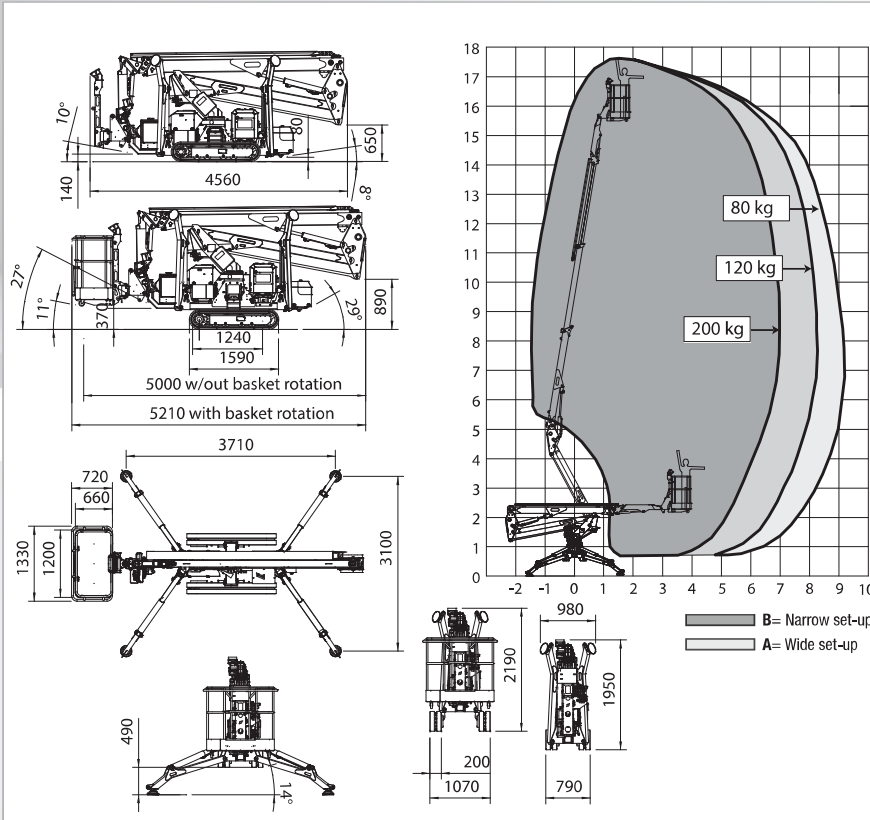

TECHNICAL SPECIFICATIONS			
	STD	E	ED
Maximum working height	m	17,60	
Floor height	m	15,60	
Maximum side outreach	m	9,20	
Rotation angle of the tower	°	360	
Aluminium basket dimensions	m	1,30 x 0,70	
Basket rotation angle	°	70+70	
Maximum capacity of basket	Kg	200	
Length closed (basket disassembled)	m	5,00 (4,36)	
Minimum width closed	mm	780	
Minimum height closed	mm	1950	
Overall dimensions Stabilization	m	3,00 x 3,66	
Maximum horizontal inclination	degrees/%	16° (29%)	
Maximum side inclination	degrees/%	17° (31%)	
Maximum speed	Km/h	1,5/2,5	0,8/1,5 1,5/2,5
<b>WEIGHTS</b>			
Weight in work conditions*	Kg	2.350*	2.500* 2650*
Ground pressure stowed machine	KN/m <sup>2</sup>		3,69
Ground pressure when on stabilizers	KN/m <sup>2</sup>		2,52
Max point load on one stabilizer	KN		17,50
<b>POWER</b>			
Honda iGX390 petrol engine	HP/rpm	13/3600	- 13/3600
Z482 Kubota diesel engine	HP/rpm	13/3200	- 13/3200
Electric Motor 230Vac/50Hz (110Vac/60Hz)	CV/KW	2,20/3 (1,50/2)	2,20/3 (1,50/2) 2,20/3 (1,50/2)
Electric Motor 24 Vdc	CV/KW	-	3,5/4,8 3,5/4,8
Traction battery 24Vdc Lead Acid capacity	Ah	-	210 300 210
Traction battery 24Vdc Lithium Ion	Ah	-	210 300 210

\* Subject to change depending on configuration.